

PLAN  
SCALE: 1/2" = 1'-0"

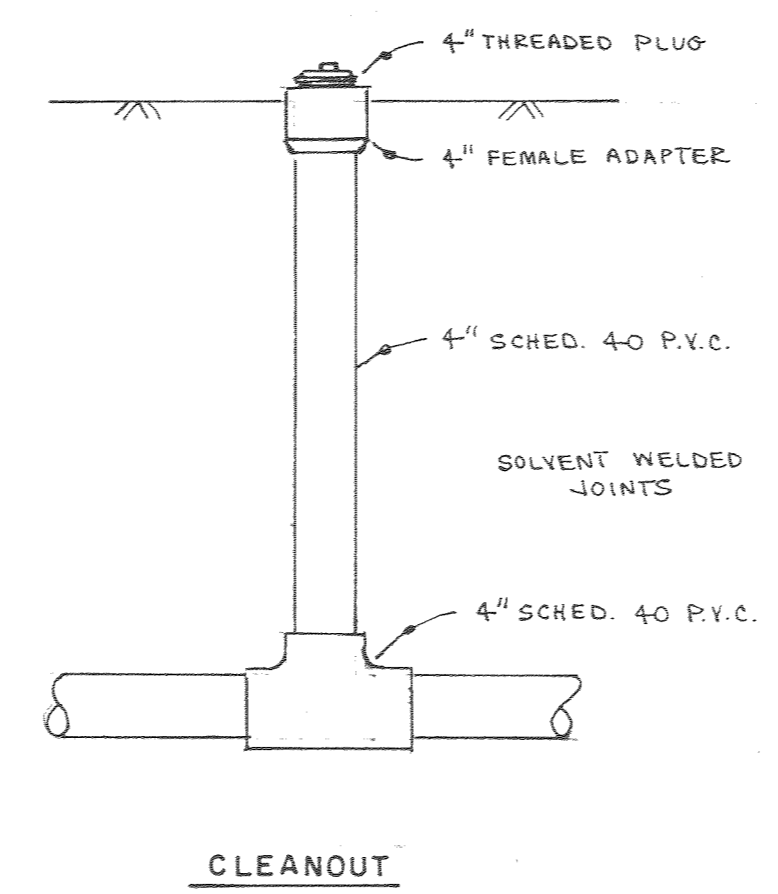

CLEANOUT

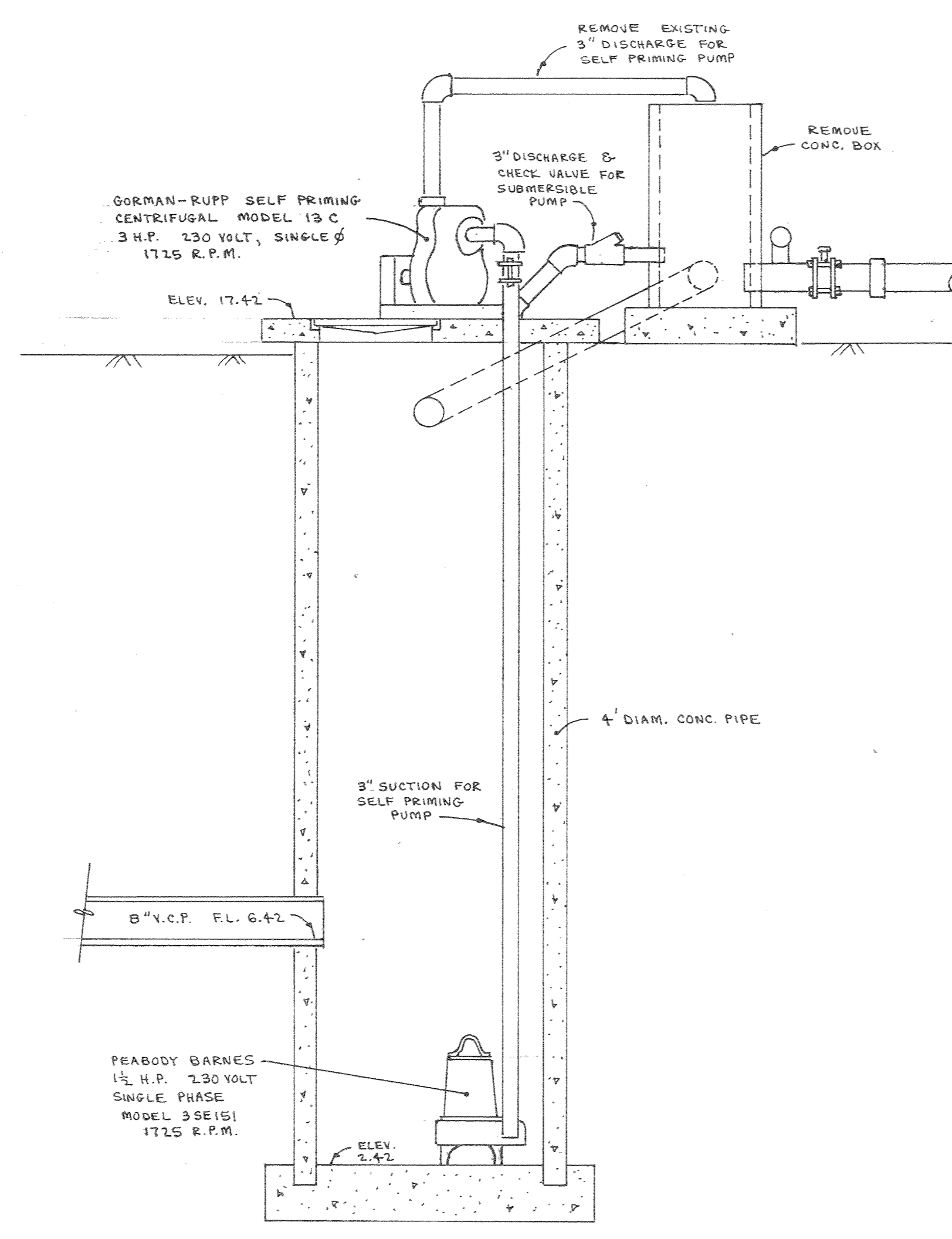

SECTION A-A  
SCALE: 1/2" = 1'-0"

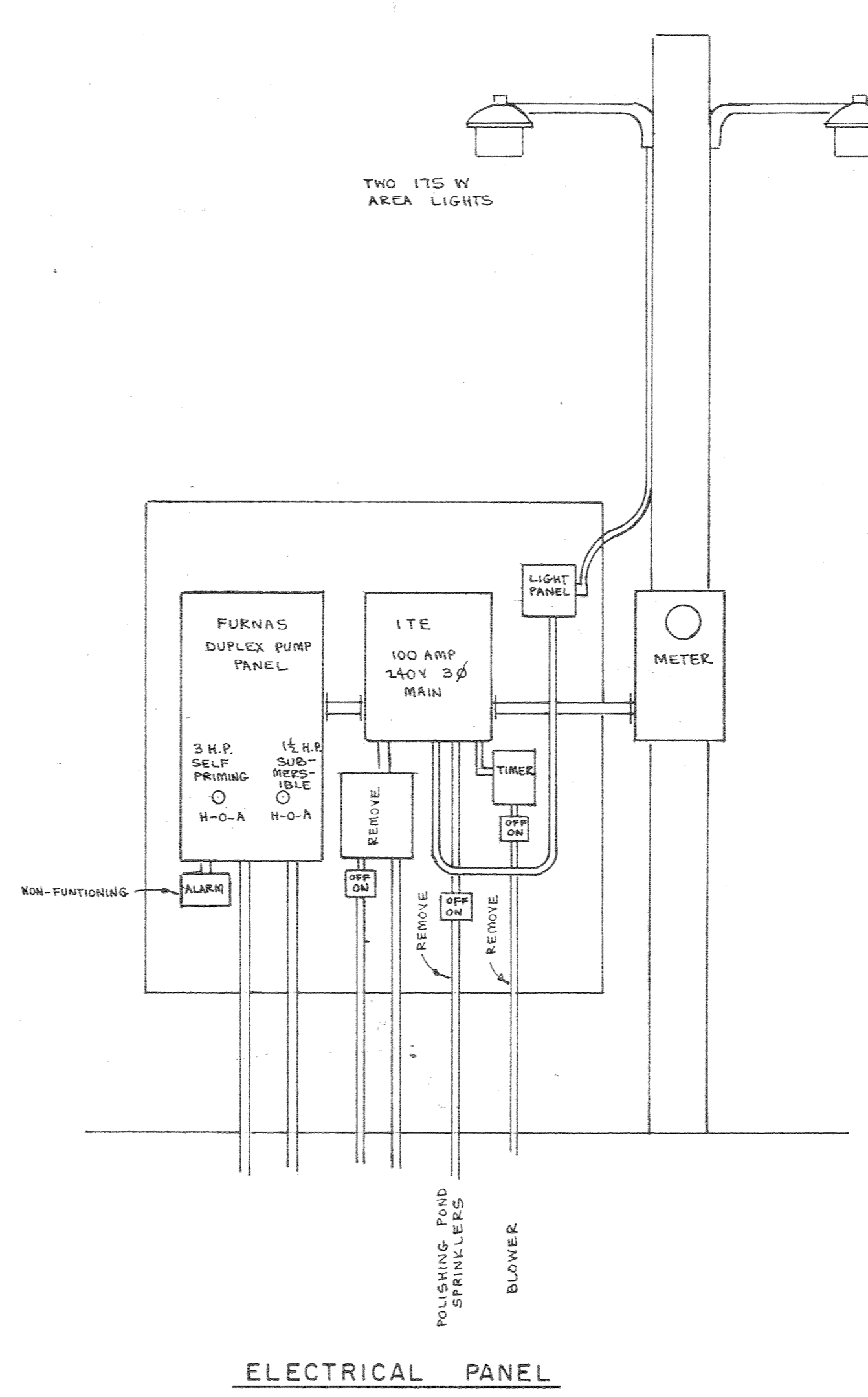

ELECTRICAL PANEL

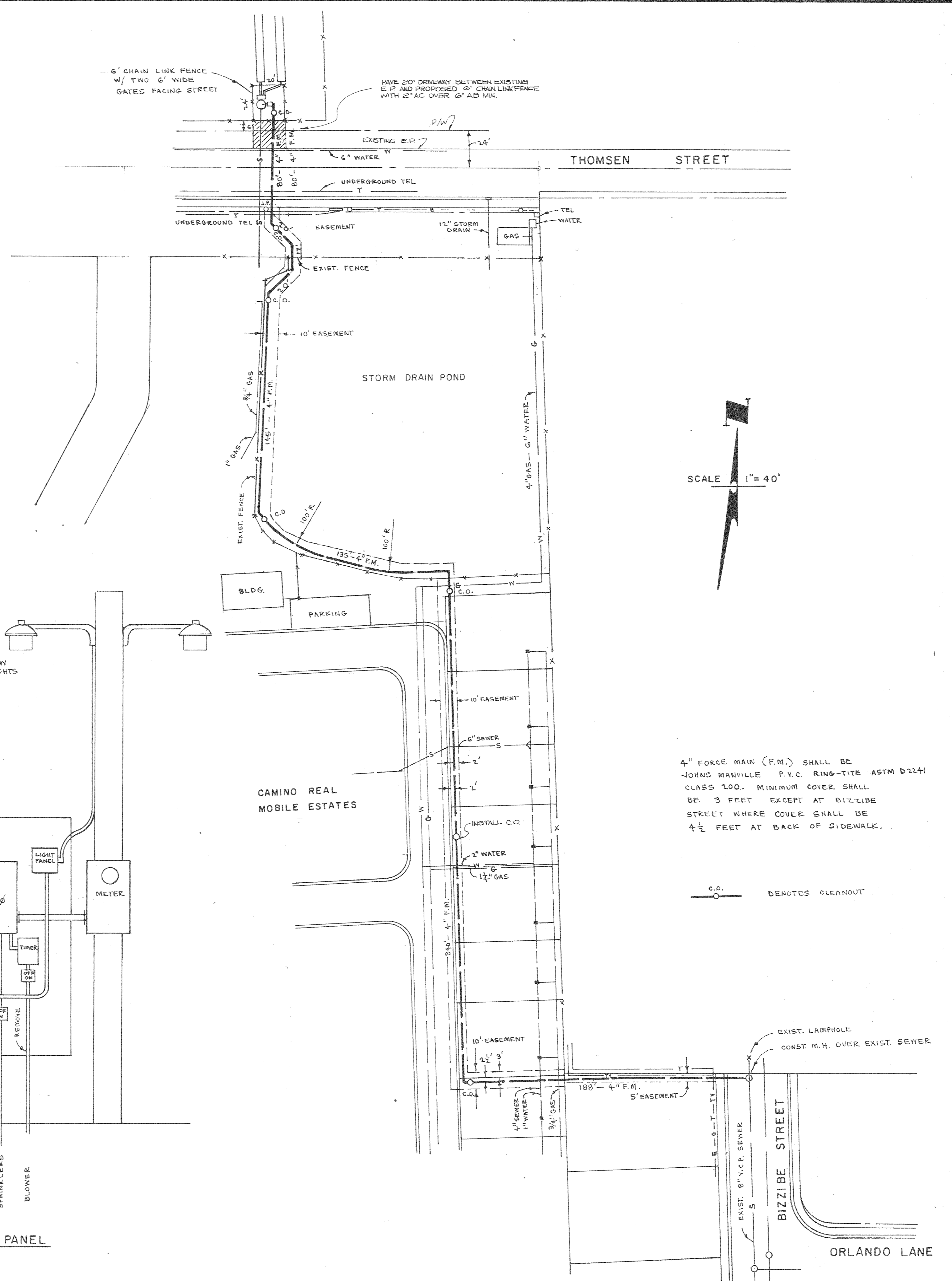

SCALE 1" = 40'

4" FORCE MAIN (F.M.) SHALL BE  
JOHNS MANVILLE P.V.C. RING-TITE ASTM D2241  
CLASS 200. MINIMUM COVER SHALL  
BE 3 FEET EXCEPT AT BIZZIBE  
STREET WHERE COVER SHALL BE  
4 1/2 FEET AT BACK OF SIDEWALK.

C.O. DENOTES CLEANOUT

FILE NAME: 30810  
 DRAWER: 50  
 SHEET NO.: 1544

APPROVED *Sept 23* 19 *82*  
*James R. Miller*  
 SAN JOAQUIN LOCAL HEALTH DISTRICT

APPROVED *09-29* 19 *82*  
*William V. ...*  
 SAN JOAQUIN COUNTY DIRECTOR OF PUBLIC WORKS  
 R. C. E. 9338

no.	description	date	by

**WONG ENGINEERS, INC.**  
 PLANNING • ENGINEERING • SURVEYING  
 STOCKTON, CALIFORNIA  
*B. Chance Wong*  
 R.C.E. No. 14269

job no. 2072  
 date SEPT 1982  
 scale AS SHOWN  
 drawn C.C.W.  
 design  
 check

**SEWAGE FORCE MAIN UTILIZING  
 EXISTING SEWAGE LIFT STATION  
 FOR CAMINO REAL MOBILE HOME PARK**

SHEET **1**  
 OF ONE  
 FILE

PRINTED ON DIEPRO NO. 1000N CLEARPRINT